



# **SVX-Series Solenoid Actuated Diesel Engine Air Shut Down Valves (Energised to Run, Hazardous Area Types without Manual Override)**

**Selection, Application and Maintenance**

Valve Numbers	
SVX-320	SVX-330
SVX-520	SVX-530
SVX-820	SVX-830

## DESCRIPTION

A range of 12 and 24 volt EExe solenoid operated diesel engine air intake closure valves based on the standard Chalwyn slimfit 3", 5" and 8" butterfly valves. These products are available in basic flange mounted form, but can also be supplied fitted with hose adaptors.

These valves are designed to "fail safe" in that if electrical power is lost for any reason the valve will revert to the closed condition.

Valve bodies and discs are all manufactured from corrosion resistant hard anodised aluminium with a PTFE coating. Spindles and mechanisms are manufactured from 316 stainless steel.

The Chalwyn 12 volt solenoid type SSX-102 built into the hazardous area valves type SVX-320, SVX-520 and SVX-820 is marked as follows:

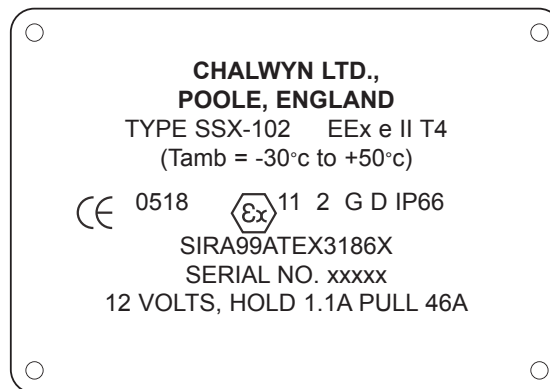

The Chalwyn 24 volt solenoid type SSX-201 built into the hazardous area valves type SVX-330, SVX-530 and SVX-830 is marked as follows:

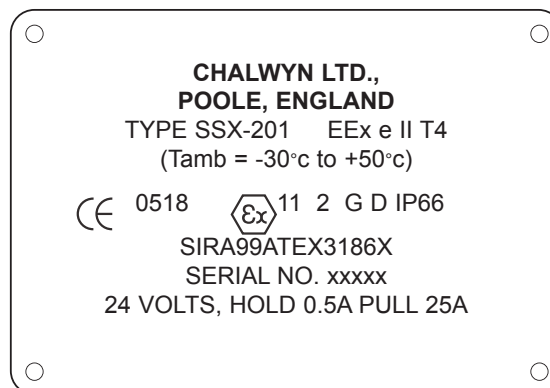

### IMPORTANT NOTES: SOLENOID TYPES SSX-102 AND SSX-201

Araldite epoxy adhesive and an elastomeric cable seal are used in the construction of these solenoids. The characteristics of these materials with regard to attack by aggressive substances shall be taken into account when installing or using the product in a hazardous area.

Solenoids SSX-102 and SSX-201 must not be mounted or installed in such a way that the effective ambient temperature exceeds 50°C.

**Typical Valve Arrangement:**

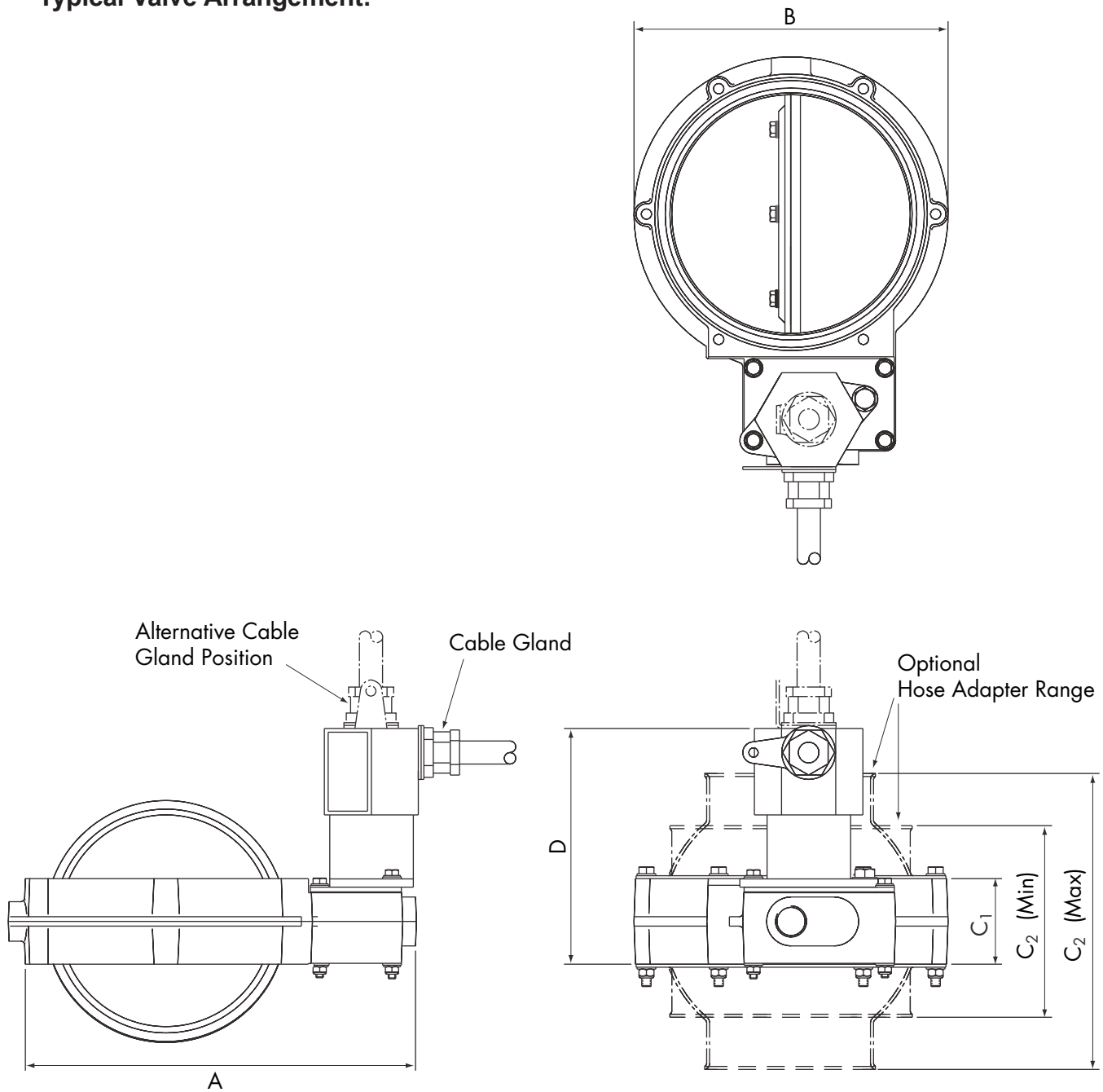

**Main Dimensions (mm)**

Valve Type	Nominal Bore Dia.	A	B	C <sub>1</sub>	C <sub>2</sub> (min & max)	D
SVX-320 SVX-330	76 (3")	161.0	111.5	37.5	82.5 to 112.5	121.5
SVX-520 SVX-530	127 (5")	217.0	167.5	45.5	102.0 to 157.5	125.5
SVX-820 SVX-830	203 (8")	317.5	257.0	56.0	136.5 to 185.5	130.5

For optional hose adaptor range see page 4.

## SELECTION

This range of valves is suitable for operation in T4, Zone 1, Gas Group IIB or in Zone 21 hazardous areas. All valves in this range have separate connections for “pull” and “hold” coils. The power supply must therefore be arranged with a suitable timer circuit to switch between the “pull” and “hold” connections.

Determine the size and position of the SVX valve to be installed. Within the various constraints imposed by the application, the valve should be as generously sized as possible. Check that the valve can be installed such that the electrical cable may be routed away without risk of damage. The standard cable gland entry point is shown on page 3. An alternative end entry position is available if specified.

If the valve is to be fitted into a hose as opposed to flange mounted, suitable hose adaptors should be selected from the table below and ordered with the valve.

### Hose Adaptor Options

76mm (3") Bore Valves	
Adaptor Part Number	To Suit Hose Bore mm (inches)
HAX-320	38 (1½)
HAX-322	44.5 (1¾)
HAX-301	51 (2)
HAX-302	54 (2 ⅛)
HAX-303	57 (2 ¼)
HAX-304	60 (2 ⅜)
HAX-305	63.5 (2 ½)
HAX-306	67 (2 ⅝)
HAX-307	70 (2 ¾)
HAX-308	73 (2 7/8)
HAX-309	76 (3)
HAX-312	82.5 (3¼)
HAX-314	89 (3 ½)
HAX-319	102 (4)

127mm (5") Bore Valves	
Adaptor Part Number	To Suit Hose Bore mm (inches)
HAX-501	89 (3 ½)
HAX-502	92 (3 ⅝)
HAX-503	95 (3 ¾)
HAX-504	98 (3 7/8)
HAX-505	102 (4)
HAX-506	105 (4 ⅛)
HAX-507	108 (4 ¼)
HAX-508	111 (4 ⅜)
HAX-509	114 (4 ½)
HAX-510	117.5 (4 5/8)
HAX-511	121 (4 ¾)
HAX-512	124 (4 7/8)
HAX-513	127 (5)
HAX-518	140 (5 ½)
HAX-523	152 (6)

203mm (8") Bore Valves	
Adaptor Part Number	To Suit Hose Bore mm (inches)
HAX-807	178 (7)
HAX-808	203 (8)

## INSTALLATION (MECHANICAL)

1. In the case of a naturally aspirated engine, the Chalwyn SVX shut down valve should generally be fitted as close to the engine air intake manifold as possible. If an air intake flame trap is also fitted, the SVX valve must be installed upstream (air cleaner side) of the flame trap.
2. If the engine is turbocharged, it may be necessary to fit the valve upstream of the turbocharger in order to avoid temperatures in excess of the maximum permitted for the solenoid (see page 2). Again if an air intake flametrap is also fitted the valve must be installed upstream of the flametrap.
3. Where more than one SVX valve is installed on an engine, as in the case of an engine with multiple intake pipes, the shut down valve control system must be arranged to ensure all valves close simultaneously.
4. This valve may be installed either horizontally or vertically.
5. If hose adaptors are used, the mating hose should be of a reinforced type, provide adequate support for the valve and prevent excessive vibration. If necessary, additional support brackets mounted from the engine should be considered.
6. Particular care must be taken to ensure the integrity of the intake pipework between the Chalwyn valve and intake manifold. Ideally metal pipework should be used and any gaps kept as short as possible, (taking into account any relative movement) and closed by reinforced hose.
7. Any engine crankcase breather connections into the intake system between the SVX valve and engine, or any internal crankcase breather arrangement venting directly into the engine intake ports must be sealed and replaced by an external breather system venting either to atmosphere or to the intake system upstream of the shut down valve. External breather system kits for various engine types are available from Chalwyn.

## INSTALLATION (ELECTRICAL)

The diagram shows a typical Chalwyn wiring arrangement for the solenoids. It is **IMPORTANT** that the start key switch for the engine is wired such that between starting attempts it is not necessary to de-energise the solenoid. The starting instructions for the operative must clearly state that the key switch should not be returned to the solenoid de-energised position whilst attempting to start. If this requirement cannot be complied with, or if the engine is an unattended unit fitted with an automatic start arrangement, the control system providing the power to the solenoid must be designed to restrict the number of times the pull coil is energised to a maximum of 6 times per 30 minutes followed by a 30 minute rest before repeating the cycle.

**Supply voltage:** 12 vdc. (SVX-320, SVX-520 and SVX-820) or 24vdc (SVX-330, SVX-530 and SVX-830)

**Pull current** at 23°C : 46 amps (12 volt types) or 25 amps (24 volt types).

**Hold current** at 23°C : 1.1 amps (12 volt types) or 0.5 amps (24 volt types).

**Pull coil:** Must not be powered for more than 0.5 seconds continuously. A suitable timer circuit must be incorporated to achieve this.

**NOTE: The control system must include a back-up safety device which de-energises the pull coil if it is energised for more than 14 seconds continuously.**

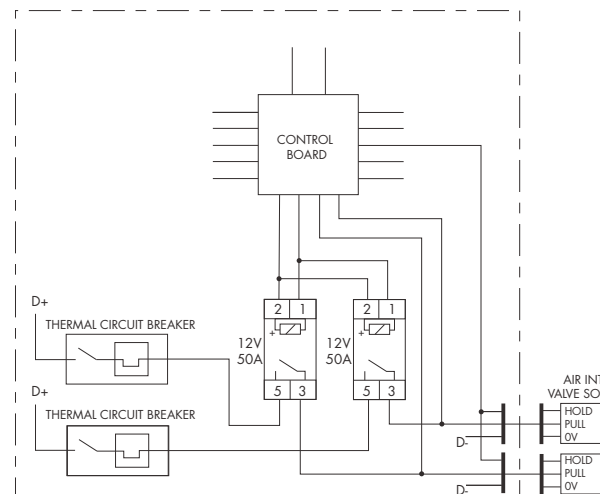

EXAMPLE OF A TYPICAL SOLENOID OPERATING CIRCUIT

The blue wire is the common return and must be connected to the negative terminal of the supply.

The yellow/green wire is the pull coil supply.

The brown wire is the hold coil supply.

The outer braiding of the supply cable should be earthed at the supply end.

The solenoid may be earthed using the earth tag of the cable gland.

### NOTES:

- a) Suitable cable glanding must be used at the supply end of the cable.
- b) The length of the supply cable should not be increased from that supplied.

---

## OPERATION

When powered the solenoid holds the air intake shut down valve in the open (engine run) condition. On loss of power the spring within the shut down valve assembly moves the valve to the closed (engine stop) position, i.e. failure of power supply gives a fail safe (engine stopped) condition.

---

## MAINTENANCE

### WEEKLY:

Visually check the valve, solenoid, cable and cable gland for damage or deterioration. Withdraw from service if significant damage or deterioration is observed.

**NOTE:**

**Chalwyn hazardous area solenoids are sealed units. The cable gland must not be loosened or removed. If a service problem occurs, the valve should be returned to Chalwyn for repair.**

---

### MONTHLY:

Check that the fasteners locating the shut down valve and any associated intake system or support bracket fasteners are securely tightened.

Check that any flexible hoses in the engine intake between the SVX valve and engine are free from damage and suitable for further service.

Run engine, preferably at low idle. Use shut down control system emergency stop to close the intake shut down valve. The engine should stop within a few seconds. If not, check there are no leaks in the engine air intake system between the SVX valve and engine. If this does not resolve the problem remove the SVX valve to return to Chalwyn for investigation.





**Chalwyn by AMOT**

sales@chalwyn.co.uk  
www.chalwyn.com

A division of Roper Industries Limited

**UK**

Western Way  
Bury St Edmunds  
Suffolk, IP33 3SZ  
Tel: +44 (0)1284 715739  
Fax: +44 (0)1284 715747

**USA**

8824 Fallbrook Drive  
Houston  
TX 77064  
Tel: +1 (281) 940 1800  
Fax: +1 (713) 559 9419

