



# **TPZ Engine Air Intake Shut Down Valves (Combined Automatic Overspeed and Air Pressure Operated Shut Down Bendix Types)**

## **Selection, Application and Maintenance**

Valve Numbers  
TPZ-103 to TPZ-312

## DESCRIPTION

A range of diesel engine air intake shut down valves which automatically close on engine overspeed or when an air pressure signal is applied. As an optional feature, TPZ valves can also be supplied with fitted cable and handle RTD-100 to also enable manual shutdown.

TPZ valves are available for all popular combinations of air intake pipe sizes and engine ratings up to 149kW (turbocharged) or 179kW (naturally aspirated). The smaller sized TPZ valves can also be supplied with an integral engine air cleaner.

This type of valve may be fitted to either naturally aspirated or turbocharged engines. It should be noted however that for a given valve setting the repeatability of the actual shut down speed has a greater scatter in the case of a turbocharged engine. However, unless for special reasons a precisely repeatable shut down speed is required, adequate protection from excessive overspeed and potential resulting damage is still achieved.

The basic dimensions for this family of valves are tabulated on page 3.

### Typical Arrangement: Valves TPZ-103 to TPZ-210

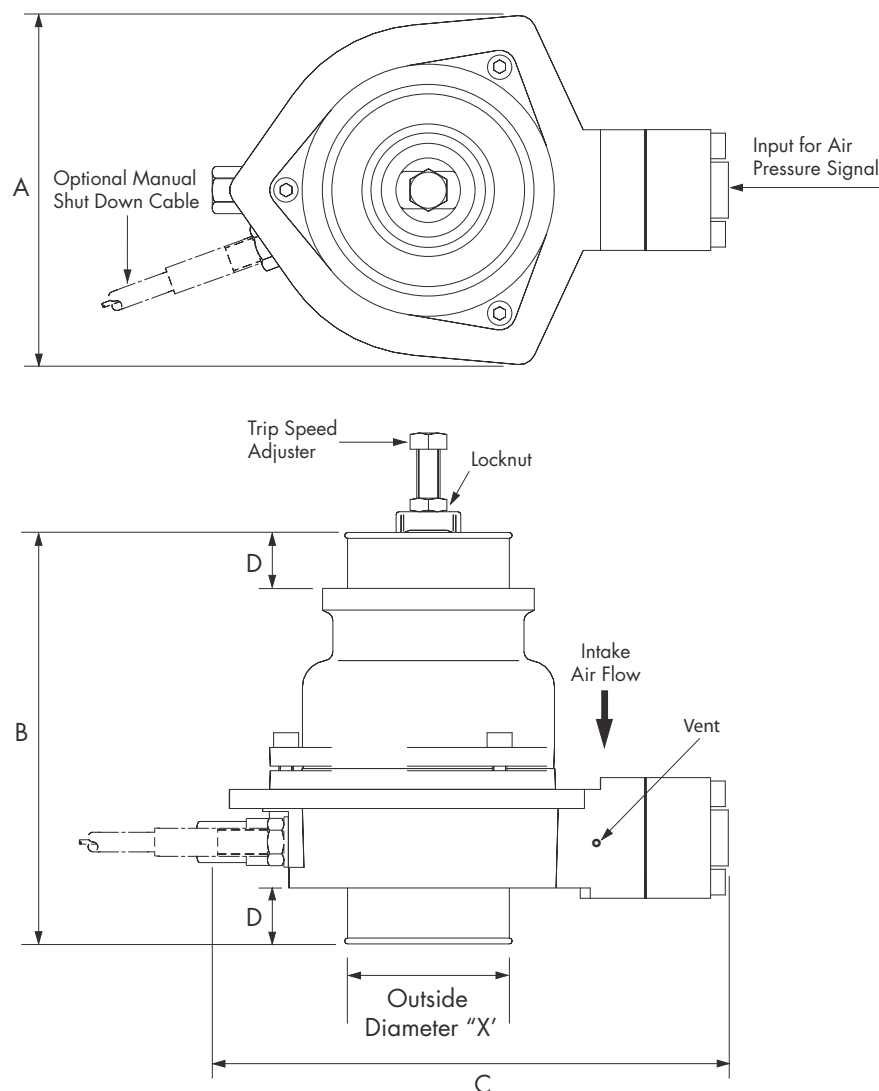

**Typical Arrangement: Valves TPZ-301 to TPZ-312**

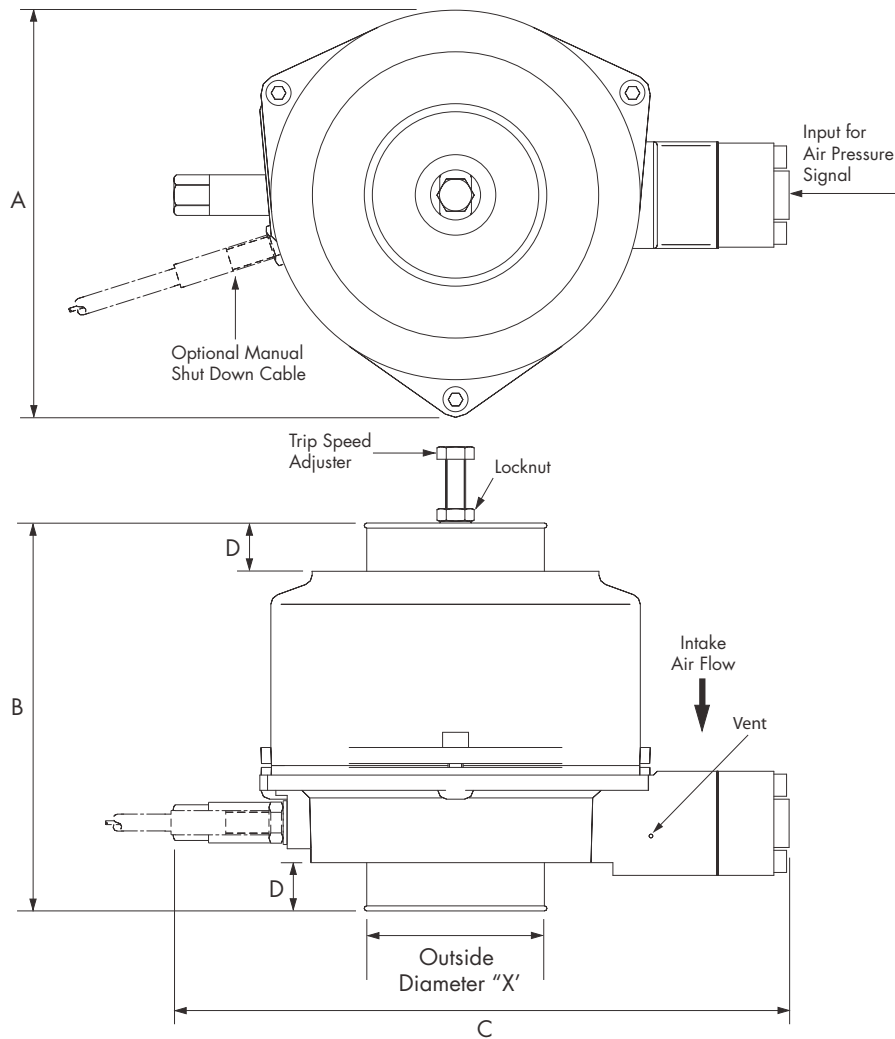

Valve Part No.				A	B	C	D	Overall length with integral air cleaner fitted	Weight
Without Air Cleaner		With Air Cleaner							
Without Manual Shut Down	With Manual Shut Down	Without Manual Shut Down	With Manual Shut Down	(mm)	(mm)	(mm)	(mm)	(mm)	(kg)
TPZ-103	TPZ-104	TPZ-203	TPZ-204	119	140	175	19	209	
TPZ-105	TPZ-106	TPZ-205	TPZ-206	119	143	175	19	212	
TPZ-107	TPZ-108	TPZ-207	TPZ-208	119	146	175	19	215	
TPZ-109	TPZ-110	TPZ-209	TPZ-210	119	147	175	19	216	
TPZ-301	TPZ-311	--	--	160	147**	242	19*	N/A	
TPZ-302	TPZ-312	--	--	160	153***	242	19*	N/A	

Outside diameter 'X' is selected to match the bore of the engine air intake hose at the position the valve is to be fitted. Dimensions marked \* increased to 25mm for outside diameter 'X' valves of 86mm or greater. Dimensions marked \*\* increased to 153mm for outside diameter 'X' valves of 86mm or greater. Dimensions marked \*\*\* increased to 159mm for outside diameter 'X' valves of 86mm or greater.

The maximum air (or oil) pressure signal applied to the TPZ valve should not exceed 10 bar (145 psi). When the engine is running, the TPZ valve will close on application of an air (or oil) pressure signal of approximately 1.5 bar (22 psi.). Note, this value varies slightly with engine speed and specific valve build.

**Note:** Where fitted, the integral engine air cleaner used with this range of valves is designed for light/medium duty applications. It should not be used for heavy duty applications as unacceptable short air cleaner service intervals may result. Further advice is available from the Chalwyn Sales Office.

## SELECTION

Determine the rating of the engine to which the valve is to be fitted and whether or not turbocharged. Using the table below identify which valve(s) would be suitable. Finalise the selection by identifying the valve which can also be supplied with end diameter(s) "X" to match the bore of the engine air intake hose at the position the valve is to be fitted. Note, end diameters are manufactured to the nearest 1mm. Generally, where more than one valve meets all requirements, select the larger valve size to minimise engine air intake restriction.

When a cable and handle for manual shut down is also required, the cable length required should be selected from the Selection Chart below and ordered together with the valve and shut down 'T' handle assembly RTD-100. (Note, other cable lengths may be available on request).

### Selection Chart - Cable

CABLE PART NO	LENGTH (metres)
CLD-100	1.0
CLD-150	1.5
CLD-200	2.0
CLD-300	3.0

### Valve selection chart in metric units

VALVE PART No.	ENGINE POWER AT RATED SPEED kW		ENGINE AIR INTAKE HOSE BORE mm	
	Naturally Aspirated Engines	Turbocharged Engines	Minimum	Maximum
TPZ-103, TPZ-104, TPZ-203 & TPZ-204	7.5 to 38	7.5 to 32	51	70
TPZ-105, TPZ-106, TPZ-205 & TPZ-206	15 to 54	15 to 45	51	80
TPZ-107, TPZ-108, TPZ-207 & TPZ-208	22 to 72	22 to 60	57	83
TPZ-109, TPZ-110, TPZ-209 & TPZ-210	30 to 93	30 to 78	63	96
TPZ-301 & TPZ-311	40 to 120	40 to 100	70	102
TPZ-302 & TPZ-312	50 to 179	50 to 149	70	108

### Valve selection chart in non-metric units

VALVE PART No.	ENGINE POWER AT RATED SPEED hp		ENGINE AIR INTAKE HOSE BORE inches	
	Naturally Aspirated Engines	Turbocharged Engines	Minimum	Maximum
TPZ-103, TPZ-104, TPZ-203 & TPZ-204	10 to 50	10 to 42	2	2 3/4
TPZ-105, TPZ-106, TPZ-205 & TPZ-206	20 to 72	20 to 60	2	3 1/8
TPZ-107, TPZ-108, TPZ-207 & TPZ-208	30 to 93	30 to 80	2 1/4	3 1/4
TPZ-109, TPZ-110, TPZ-209 & TPZ-210	40 to 125	40 to 104	2 1/2	3 3/4
TPZ-301 & TPZ-311	54 to 161	54 to 134	2 3/4	4
TPZ-302 & TPZ-312	67 to 240	67 to 200	2 3/4	4 1/4

## FITTING

1. When supplied without integral engine air cleaners, this family of Chalwyn valves should generally be fitted as close to the engine air intake manifold as possible. Where an engine air intake flametrap is also fitted, the Chalwyn valve must always be positioned on the upstream (air cleaner) side of the flametrap. These same requirements are generally applicable to both naturally aspirated and turbocharged engines but, in the case of a turbocharged engine, the following may be applicable.

- a) Insufficient space to fit between the turbocharger and engine. In this case the valve may be fitted upstream of the turbocharger.
- b) The turbocharger air outlet temperature is in excess of 180°C /356°F. In this case fit the valve downstream of the intercooler or upstream of the turbocharger.

2. When supplied with an integral air cleaner, this type of Chalwyn valve is fitted in place of the existing air cleaner.

3. Where more than one Chalwyn valve is fitted to an engine, as in the case of an engine with multiple intake pipes, a balance pipe arrangement must be installed to connect the various intake pipes together downstream (engine side) of the shut down valves. Typically balance pipe diameters should be about 30% of the diameter of the intake pipes.

4. When fitting, ensure the direction of air flow:-

- a) Is in compliance with direction indicated on the body.
- b) Is between vertically downward and horizontal.

5. The flexible cuffs at the inlet and outlet of the valve should be of a re-inforced type, provide adequate support for the valve and prevent excessive vibration. If necessary, additional support brackets mounted from the engine should be considered.

6. Particular care must be taken to ensure the integrity of the intake pipework between the Chalwyn valve and intake manifold. Ideally metal pipework should be used and any gaps kept as short as possible, (taking into account any relative movement), and closed by re-inforced hose. The possibility of a hose collapse on closure of the shut down valve should be avoided.

7. Any engine crankcase breather connections into the intake system between the Chalwyn valve and engine or any internal crankcase breather

arrangement venting directly into the engine intake ports must be sealed and replaced by an external breather system venting either to atmosphere or to the intake system upstream of the shut down valve. External breather system kits for various engine types are available from Chalwyn.

8. When fitting a TPZ with manual stop option, position the 'T' handle assembly RTD-100 to ensure a reasonably straight cable run. Fit the 'T' handle assembly RTD-100 through a suitable Ø20mm (¾" diameter) hole in a bulkhead or mounting bracket as follows. Release the handle locknut. Remove the handle, handle locknut and upper locknut and washer. Thread handle body through the bulkhead/ bracket. Refit upper locknut and washer. Adjust lower and upper locknut to position handle and tighten. Refit handle locknut and handle. Tighten locknut.

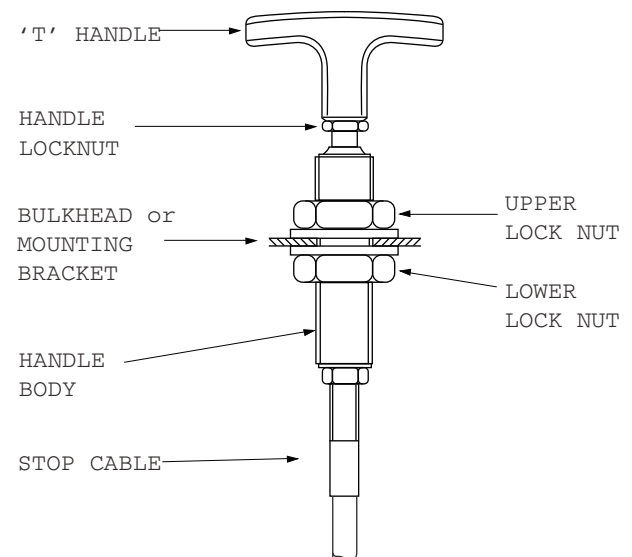

9. Connect supply pipe for air pressure shut down signal to port provided in the shut down valve. Ensure that this supply is vented to atmospheric pressure other than when an air pressure tripped shut down is required.

**See Important Notes over page**

**Important Notes.**

- a) In addition to a TPZ valve, an engine fuel stop must always be retained to enable a normal engine shut down.
- b) The collar inside the valve and the short internal cable which it anchors are factory set and must not be loosened or adjusted.
- c) For valves with the manual shut down option, if the manual shut down cable is replaced, thread the cable inner through the drilling provided in the internal collar until the copper end stop abuts against the collar but do not loosen or adjust the position of the collar.

## ADJUSTMENT

Once the Chalwyn valve is installed, adjustment of the overspeed trip setting is carried out using the adjuster and locknut (refer to diagrams). Basically rotating the adjuster clockwise will increase the engine speed at which automatic shut down occurs.

As supplied, the valve will be adjusted such that shut down will generally occur well below the engine high idle speed. To increase the speed at which automatic shut down occurs, proceed as follows:

1. If a remote 'T' handle stop control is fitted, make sure the 'T' handle is in the "run" position (ie. pushed in).
2. Ensure no shut down signal is being applied by the air pressure shut down system.
3. Start engine. Slowly accelerate. Note speed at which shut down occurs.
4. Remove the hose at air inlet to Chalwyn valve to expose the adjuster and locknut (see diagram).
5. Release locknut. Turn adjuster clockwise one turn. Tighten locknut.
6. Refit inlet hose to Chalwyn valve.
7. Start engine. Slowly accelerate. Note speed at which shut down occurs.
8. Repeat steps '4' to '7' until the first setting at which the engine does not shut down at high idle speed (i.e. maximum throttle, no load). Then either:
  - a) *Use the results of shut down speed versus adjuster setting as a calibration check to make a final adjustment to give the required setting (typically 10% to 15% over high idle).*
  - or**
  - b) *If a very precise setting is not required, turn the adjuster a further one turn clockwise to take the shut down above high idle speed by a suitable margin. When using this setting procedure it may be found that the engine occasionally shuts down during the normal operation. If so, turn the adjuster clockwise by a further one half turn.*
9. Ensure the adjuster locknut is fully tightened. Use a thread lock adhesive on the locknut threads).
10. Restart engine. Run at low/medium speed. Apply air pressure shut down signal of between 2 and 10 bar. The engine should stop within a few seconds.
11. When fitted with a remote control 'T' handle stop control, restart the engine and operate (pull) the 'T' handle. This should stop the engine within a few seconds

### Notes:

#### **Turbocharged Engines.**

When setting a valve fitted to a turbocharged engine using the preceding method, it may be found that at high engine power outputs, the engine will shut down at a lower speed than required. If this occurs, further small adjustments in steps of one half turn clockwise should be made until the problem is eliminated.

#### **Jammed Valve.**

If in the course of adjusting the valve it jams on its seat, release by turning **CLOCKWISE** viewed from adjuster end.

## MAINTENANCE

Routine maintenance should be undertaken as given below. **Note:** not all valve variants include an integral air cleaner and, or, manual shut down.

**Daily:** Run engine at low/medium speed. Apply air pressure shut down signal. The engine should stop within a few seconds.

### Three Monthly:

1. With the engine not running, apply the air pressure shut down signal and check for air leakage through the valve vent holes (see diagrams pages 2 and 3). If leakage is detected this may indicate a damaged diaphragm. This must be rectified before the unit is returned to service.
2. Disconnect intake pipework and release the valve from any support brackets etc. to allow it to be removed.
3. Inspect the valve internally for cleanliness. If necessary clean in paraffin or white spirit taking normal precautions. Dry the valve thoroughly.
4. Check there is no excessive wear and that the valve moves smoothly over its complete operating strokes. **DO NOT LUBRICATE.**
5. Refit valve. Check valve setting based on the "Adjustment" instructions given herein.
6. Run engine at low/medium speed. Apply air pressure shut down signal. The engine should stop within a few seconds.
7. When fitted with a remote 'T' handle stop control, restart the engine and operate the manual shut down. The engine should stop within a few seconds

**Integral Engine Air Cleaner** (where fitted)  
Replace air cleaner element at the periods recommended by the engine manufacturer. (Spare elements are available from Chalwyn)

#### Important Notes:

The three monthly routine maintenance period requirement is dependent on the operating conditions to which the equipment is exposed and, by experience, may need to be varied.

Any maintenance problems not covered by the above routine maintenance schedule should be discussed with your Chalwyn Distributor before any repair work is undertaken

#### Chalwyn by AMOT

sales@chalwyn.co.uk  
www.chalwyn.com

A division of Roper Industries Limited

#### UK

Bury St Edmunds, IP33 3SZ  
Tel: +44 (0)1284 715739  
Fax: +44 (0)1284 715747

#### USA

Houston, TX 77064  
Tel: +1 (281) 940 1800  
Fax: +1 (713) 559 9419

